

# Photoluminescent Distinction Among Plant Life Forms Using Phosphate Buffered Saline Extract Solutions

TIMOTHY L. DANIELSON,\* SAFWAN OBEIDAT, GARY D. RAYSON,†  
DEAN M. ANDERSON, ED L. FREDRICKSON, and RICK E. ESTELL

Department of Chemistry and Biochemistry, New Mexico State University, Las Cruces, New Mexico 88003 (T.L.D., S.O., G.D.R.); and Jornada Experimental Range, USDA-ARS, Las Cruces, New Mexico 88003 (D.M.A., E.L.F., R.E.E.)

Photoluminescence of plant extract solutions has been investigated for discrimination of plant life forms (grasses, forbs, and shrubs) using principal component analysis (PCA). Clippings from each of six plant species representing three different plant life forms potentially found in the diets of free-ranging herbivores in the Chihuahuan Desert of North America were investigated for possible discernment. These plants included *Sporobolus flexuosus* (mesa dropseed, a grass), *Pleuraphis mutica* (tobosa, a grass), *Dimorphocarpa wislizenii* (spectacle pod, a forb), *Sphaeralcea incana* (pale globemallow, a forb), *Flourensia cernua* leaves (tarbush, a shrub), and *Atriplex canescens* leaves and stems (fourwing saltbush, a shrub). Emission spectra (370–600 nm) from phosphate buffered saline (PBS) extract solutions (pH 2.2, 7.5 and 12.5) were recorded for each plant with excitation at 365 nm. Use of PBS minimized chlorophyll interference. Discernment among plant life forms within these plant species was achieved.

Index Headings: Photoluminescence; Principal component analysis; PCA; Plant life forms; Standing crop; Botanical composition.

## INTRODUCTION

There is a need for a rapid, accurate, and noninvasive procedure for determining the botanical composition of free-ranging herbivore diets. Presently, micro-histological examination of digesta or fecal matter and direct observation of foraging animals are two of the most frequently used techniques for determining the diets of free-ranging animals.<sup>1–3</sup> These two methods, however, are tedious and require many hours by trained individuals in order to obtain reasonable estimates. In addition, both techniques are biased by observer influence. Specifically, these techniques involve the analysis of esophageal or ruminal samples of digesta. These methods are highly invasive and require removal of material from the animal's digestive tract for analysis. Even with the use of microscopic procedures<sup>4</sup> and plant fragment reference libraries,<sup>5,6</sup> mastication and differential digestion frequently reduce dietary material to unidentifiable sizes that are beyond the capabilities of visual acuity. Alternately, less invasive observer-based techniques (e.g., bite-counts) can modify the animal's behavior and raise questions regarding the validity of the data acquired.

Spectrochemical analysis techniques focus on the molecular composition of the plants. Replacement of visual acuity with more objective spectroscopic instrumentation offers the potential for rapid and efficient determinations of diet composition for real-time range-land management (e.g., through the analysis of feces). However, the use of spectroscopic techniques as tools for the elucidation of animal diet

botanical composition requires demonstration of sufficiently unique spectral signatures corresponding to different plant forage samples prior to its application to fecal samples.

One successful spectroscopic approach has been the use of near-infrared reflectance spectroscopy (NIRS). As a mature spectroscopic technique,<sup>7,8</sup> NIRS has been applied to studies in range-animal ecology. Specifically, it has been successfully applied to the estimation of species composition in mixed pastures,<sup>9</sup> the prediction of leafy spurge percentage in sheep diets,<sup>10</sup> and the determination of leaf-to-stem ratios in hand-clipped samples of grasses (big bluestem, smooth brome grass, and switchgrass plants).<sup>11</sup>

The photoluminescence spectral signatures of plants offer the possibility for use as an alternate rapid method for their discrimination.<sup>12</sup> Terrestrial plants tend to emit light in two regions of the visible spectrum (i.e., red and blue-green). The red region of the spectrum is typically dominated by chlorophyll fluorescence. The identification of the molecular species responsible for the blue-green fluorescence (BGF, 375–620 nm) has been less well defined. Lichtenthaler and Schweiger<sup>13</sup> have reported luminescence in this spectral region to be dominated by ferulic acid bound to the cell walls of a variety of plants.

The efficiency with which chlorophylls are extracted using both polar and nonpolar solvents (e.g., chloroform and hexane, respectively) has hindered the utility of luminescence in the blue to green spectral regions for plant species identification. Photoluminescence measurements from samples containing chlorophyll can result in errors in the analysis of extract solutions from different plant species because of the chlorophyll absorption band in that spectral window. Measurement is further complicated by variability in chlorophyll concentrations within a species due to growing conditions.<sup>14</sup> Time of day, time of year, drought conditions, and actinic light exposure are among the parameters reported to affect chlorophyll concentrations.<sup>14–18</sup>

Previously, blue to green luminescence ratios in intact leaves have been used to differentiate among plant species.<sup>19,20</sup> Unfortunately, both emitting and absorbing compounds are often localized within intact plant samples.<sup>13</sup> This can influence the recorded fluorescence signature depending on the cross-section of the sample illuminated. For example, epidermal anthocyanins can absorb green fluorescence, resulting in an increase in the BF/GF (blue fluorescence to green fluorescence) ratio. Alternately, the large emission bandwidth of blue fluorophores (i.e., that produced by hydroxycinnamic acids) can impact the measured signal in the green region of the spectrum.<sup>20</sup> The use of homogeneous plant-extract solutions enables the acquisition of a spectral signature more representative of the whole plant. It is anticipated that the establishment of a database of spectral signatures for plants species within

Received 5 December 2005; accepted 10 April 2006.

\* Present address: Philip-Morris Co., Richmond, VA.

† Author to whom correspondence should be sent. E-mail: garayson@nmsu.edu.

a given foraging area or season will enable the identification of plants using photoluminescence measurements.

Luminescence spectra have been applied to the investigation of alternate complex mixtures derived from plants<sup>21,22</sup> and food products.<sup>23</sup> For example, Seiden et al.<sup>24</sup> have described the exploration of fluorescence spectra from each of two excitation wavelengths as a means of evaluating the quality parameters associated with apple juice from each of two varieties. Although they were unable to demonstrate a clear correlation between the spectral signatures of each sample with more typical quality parameters, they were able to segregate the juice from each variety through the application of principal component analysis (PCA) to the respective emission spectra.<sup>24</sup> Alternatively, Baunsgaard et al.<sup>25</sup> demonstrated the utility of fluorescence emission spectral signatures for the discernment of the processing history of sugar samples.

Previous research<sup>26,27</sup> suggests that differences exist among the emission spectra for different plant species. Differences in emission spectral signatures among plant species due to unique combinations of luminescent (and absorbing) molecular species creates an opportunity for rapid and accurate species determinations of pre-digested and possibly post-digested plant materials.<sup>13</sup>

In this study, a phosphate buffered saline (PBS) solution was observed to be the preferred extraction solvent, showing considerable reduction of the observed chlorophyll fluorescence compared to organic solvents (e.g., chloroform and hexane). Aqueous buffered saline solutions provide a means of potentially observing species-dependent contributions of luminescent compounds to plant spectral signatures.

## EXPERIMENTAL

**Sample Preparation.** Material from five different individual plants of each of six species representing two grasses, two forbs, and two shrubs were harvested between August 6 and October 2, 1996, on the United States Department of Agriculture's Jornada Experimental Range (JER). This range is located in the Chihuahuan Desert approximately 12 km north of Las Cruces, New Mexico, in the Jornada del Muerto basin. The grasses sampled were *Sporobolus flexuosus* (mesa dropseed) and *Pleuraphis mutica* (tobosa). The forbs were *Dimorphocarpa wislizenii* (spectacle pod) and *Sphaeralcea incana* (pale globemallow). The shrub samples were from *Flourensia cernua* leaves (tarbush) and *Atriplex canescens* stems and leaves (fourwing saltbush current year's growth). Tarbush leaves were harvested from plants growing in two locations, while the current season's growth, composed of young stems and leaves, was harvested from fourwing saltbush plants. Selection of plant parts was based on those parts typically consumed by sheep and beef cattle as observed during other diet-selection studies.<sup>12</sup>

Herbaceous plants were clipped at ground level and placed in labeled paper bags and immediately oven-dried at 60 °C in a forced-air oven to constant weight. Leaves and stems from tarbush and fourwing saltbush were treated in the same manner. After oven drying, each of the 30 plant samples was individually ground to pass a 1-mm micro-Wiley mill screen and individually stored in amber colored plastic vials at room temperature. In preparation for extraction, the contents of each vial were poured into separate aluminum weighing boats and re-dried at 60 °C to remove any subsequently adsorbed moisture. Although volatile compounds in the materials were

undoubtedly lost during this procedure, the temporal stability of the resulting samples was improved. This stabilization of the samples enabled samples to be processed over a period of time, minimizing the impact of any plant-to-plant variations present in fresh plant clippings. Triplicate 0.1500 g dried samples from each plant were weighed into 16 × 125 mm borosilicate glass culture tubes (Kimble, Vineland, NJ). The tubes (a total of 90 for each solvent) were sealed with Parafilm® and left at room temperature until addition of the extracting solvent.

Five Labindustries Repipet® II Dispensers (Barnstead/Thermolyne, Dubuque, IA) were each calibrated to deliver 10.0 mL of solvent to each sample tube. The five different solvents specifically used were high-performance liquid chromatography (HPLC) grade chloroform (CHCl<sub>3</sub>) stabilized with ethanol (Spectrum Chemical, Gardena, CA); hexane (Spectrum Chemical, Gardena, CA); and each of three PBS solutions (pH 2.12, 7.21, and 12.61). The pH of each PBS solution was adjusted by the drop-wise addition of either concentrated HCl or a 50% (wt./wt.) NaOH solution. The HCl and NaOH were both obtained from Fisher Scientific. PBS solutions each contained 10.0 mM Na<sub>2</sub>HPO<sub>4</sub>, (Chempure lot M284), 2.7 mM KCl (Baker, lot no. 02335), 116 mM NaCl (Fisher, lot no. 715663), and 2.03 mM sodium azide, NaN<sub>3</sub> (Matheson Coleman & Bell), to inhibit microbial growth. Solution pH was monitored using a combination electrode (Orion, model 915600) and meter (model 710A). All aqueous solutions were prepared using nanopure water (18 MΩ, Barnstead International, Dubuque, IA).

Sample volumes of either chloroform or hexane solvents were added to the glass culture tubes containing ground plant material and mixed using a Model 231 Touch Mixer (Fisher Scientific, Pittsburgh, PA) to ensure uniform wetting of ground materials. Following mixing, the samples were left motionless for 24 hours before being filtered through Whatman No. 4 paper. Ground plant samples with PBS were mixed for one hour on a junior orbital shaker (Labline Instruments Inc., Melrose Park, IL) at 900 rpm. This contact time was found to be sufficient to enable complete wetting of the ground material, verified by visual observation of the samples. The test tubes were removed from the shaker and the contents were immediately filtered through Whatman No. 4 paper<sup>28</sup> into clean, labeled, glass tubes, which were sealed with Parafilm® before being returned to the test tube racks, and then stored at -20 °C (organic solvents) or at 3 °C (aqueous samples) to minimize evaporative losses.

**Instrumentation.** A schematic representation of the instrument configuration is shown in Fig. 1. A 500 W Xe/Hg arc lamp (model 8530, Oriel Corporation of America, Stamford, CT) provided the excitation radiation. The wavelength of excitation was selected using a 0.25 m monochromator (model HR-20, ISA Instruments, Inc., Edison, NJ), MC<sub>1</sub>. Stray-light rejection was enhanced by a band-pass absorption filter that enabled transmission of the 365 nm excitation radiation ( $\lambda_{\text{max}} = 360$  nm, full-width at half-maximum (FWHM) = 45 nm, Edmund Scientific, Barrington, NJ), F<sub>1</sub>. Following a collimating lens, L<sub>1</sub> (focal length = 7.5 cm, 2.54 cm diameter), a quartz-plate beam splitter, BS, provided reference signal detection by a photomultiplier tube (PMT<sub>1</sub>, model 1P28, RCA) through a 61 cm length of cable with a bundle of glass optical fibers. The signal from PMT<sub>1</sub> was directed to a current-to-voltage amplifier (constructed in-house) and subsequently digitized using an 8-bit analog-to-digital converter, ADC (model SR245,

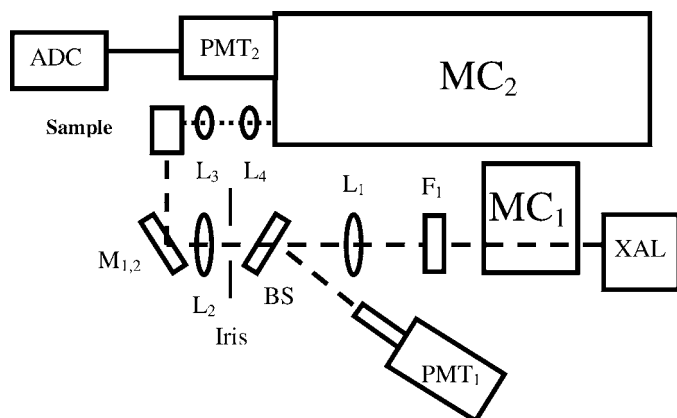

Fig. 1. Photoluminescence instrumentation schematic. The spectrometer consisted of two quartz collimating lenses ( $L_1$  and  $L_3$ ), and two quartz imaging lenses ( $L_2$  and  $L_4$ ), two flat front surface mirrors ( $M_1$ ,  $M_2$ ) and a quartz beam splitter ( $B_S$ ) having a 4% reflectance. The xenon arc lamp (XAL) was the excitation source. Excitation and emission wavelengths are selected using  $MC_1$  and  $MC_2$  monochromators, respectively. Stray radiation is minimized using an absorption filter,  $F_1$ , and an iris. Detection of the reference and analytical signals is accomplished using photomultiplier tubes ( $PMT_1$  and  $PMT_2$ , respectively). The analog-to-digital converter (ADC) was used for digitization of the PMT outputs.

Stanford Research Systems, Sunnyvale, CA). An iris with a diameter of 1.5 cm was placed in the collimated beam to further enhance stray-light rejection.

A focusing lens,  $L_2$  (focal length = 31.5 cm, 2.54 cm diameter), imaged the incident radiation through the bottom of a quartz sample cell using a combination of two folding mirrors,  $M_1$  and  $M_2$ . The emitted luminescence was first collected using a collimating lens,  $L_3$  (focal length = 5.0 cm, 2.54 cm diameter), and then focused using a camera lens,  $L_4$  (focal length = 22.1 cm, 2.54 cm diameter) on the 2.00 mm entrance slit of a 1.0 m monochromator (model 2051, GCA/McPherson Instruments, Chelmsford, MA),  $MC_2$ . This lens combination enabled the optimum collection and transfer of the emitted radiation.<sup>29</sup> The  $MC_2$  was a Czerny–Turner type monochromator equipped with a  $1200\text{ mm}^{-1}$  holographic grating with a bandpass of 1.7 nm (2.0 mm entrance and exit slit widths). Unfortunately, the use of a holographic grating resulted in the observation of the Wood's grating anomaly.<sup>30–32</sup> This was manifested as an apparent local minimum in all spectra at  $\sim 515\text{ nm}$ . Because the purpose of this study was not to identify the molecular species responsible for each feature of the recorded spectra but to use the entire resulting spectral signatures to distinguish among plant species, further correction for this anomalous feature was not undertaken. It should therefore be noted that the spectra reported using this system may not be directly transferable to other systems.

The sample holder was constructed of black Teflon™ and was designed for bottom illumination with a side window for fluorescence emission collection. A razor blade attached to the bottom surface served as a field stop to minimize stray scattered radiation. The razor blade also assisted in defining the geometry of illumination within the sample to minimize post-filter effects in the collected emission spectra.

The emitted radiation intensity was measured using a photomultiplier tube,  $PMT_2$  (Model R955) in a water-cooled PMT housing (model 3461, Pacific Precision Instruments, Concord, CA). The slit widths were optimized for maximum signal intensity with maximum resolution (i.e., minimum bandpass).

Signal acquisition and processing used a current amplifier (model 427, Keithly Instruments Inc., Cleveland, OH) with a gain of  $10^7$  and a rise time of 300 ms. The amplified analytical signal was then directed into a boxcar averager (model SR250, Stanford Research Systems, Palo Alto, CA). The averaged output (30 samples) was similarly digitized using an 8-bit ADC (model SR245, Stanford Research Systems).

Data transfer and instrument control were achieved using an IEEE-488 (GPIB) interface, GPIB-PCI (National Instruments, Austin, TX), with a 233 MHz Pentium PC running Windows 95b. Data acquisition was accomplished using in-house developed software using LabView® 5.0 (National Instruments). Data analysis utilized algorithms found in the PLS Toolbox (Eigenvector Research, Wenatchee, WA) operated within MATLAB (Mathworks, Lowell, MA).

## RESULTS AND DISCUSSION

As indicated previously, each of three types of solvents (a non-polar organic (hexane), polar organic (chloroform), and aqueous solutions (PBS) at three pH values) were initially investigated. The use of chloroform and hexane each resulted in the extraction of significant amounts of chlorophyll, as demonstrated by the intense red emission observed at 690 and 735 nm (Figs. 2A and 2B, respectively). Use of PBS (pH 7.5) yielded spectra with a much greater relative contribution in the blue region of the spectrum with drastically reduced observed chlorophyll fluorescence (Fig. 2C).

The blue-green region of the spectrum was further investigated for comparison of the three different plant life forms. One plant was selected to represent each life form: mesa dropseed (grass); spectacle pod (forb); and tarbush leaves (shrub). Figure 3 shows normalized mean spectra ( $n = 3$ ) for each plant sample. The spectra were normalized to their respective maxima between 420 and 480 nm to better illustrate spectral variations.

The mesa dropseed extract using hexane (Fig. 3A) yielded very low signal intensities, as demonstrated by the elevated noise levels and the large relative contribution of the solvent's Raman band at  $\sim 405\text{ nm}$ . For this particular grass, extraction with chloroform exhibited increased contributions to the green portion of its signature relative to that in the blue region of the spectrum. Along with the chloroform, the PBS filtrate at pH 7.5 yielded a spectrum that exhibited good signal-to-noise ratios for mesa dropseed filtrate. However, the spectral responses obtained from spectacle pod filtrate demonstrated both similar signal-to-noise and shapes for each of the three solvents used (Fig. 3B). Extracts from tarbush leaves exhibited similar spectral signatures for both the PBS at pH 7.5 and chloroform solvents. However, the use of hexane was observed to result in an increase in the relative contribution of blue emission compared to that of the green region of the visible spectrum (Fig. 3C). Solvent-dependent variations in the spectra for these plants may be impacted by solvatochromic shifts due to variations in the polarizability of the three solvents.<sup>33</sup> However, such solvent interactions are not able to fully explain the observed plant-dependent spectral characteristics. For example, mesa dropseed extracts yielded spectra with no detectable shifts with solvent polarity (i.e., hexane and PBS, Fig. 3A). Conversely, tarbush leaves extracted by each of the two polar solvents (chloroform and PBS) also produced comparable spectra (Fig. 3C). These would suggest differences in the

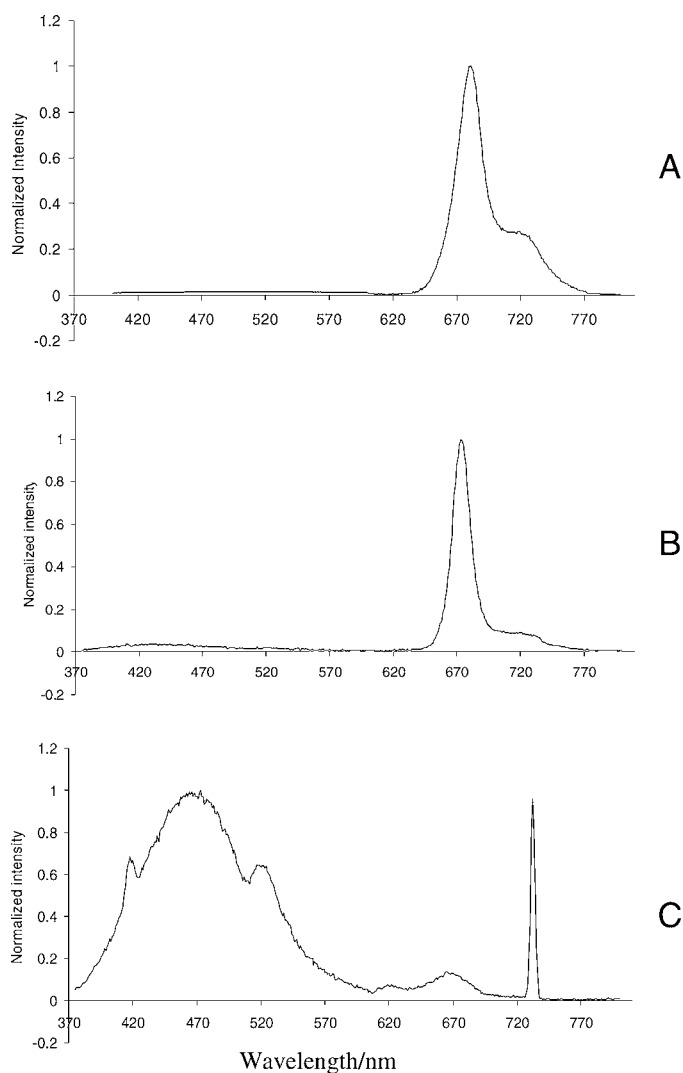

FIG. 2. Emission spectra of *Dimorphocarpa wislizenii* (Engelm.) Rollins (spectacle pod, a forb) filtrates using three solvents: (A) chloroform, (B) hexane, and (C) phosphate buffered saline, pH = 7.5.

chemical species extracted or their relative extraction efficiencies for the different species.

Conversely, Lichtenhaler and Schweiger reported insignificant variations in blue-green luminescence for different plant species.<sup>13</sup> Unfortunately, those investigators also reported decreases in the reported emission spectra as instrumentation artifacts arising from the inclusion of a cut-off absorption filter within the collection optics of their experimental configuration.<sup>13</sup>

The chlorophyll emission bands at 690 and 735 nm are evident in spectra obtained from chloroform and hexane solvents (Figs. 2A and 2B). In contrast, chlorophyll emission was undetectable with the use of PBS at pH values of 2.2, 7.5, and 12.5 (Figs. 4A–4F). PBS solutions were therefore used for all subsequent measurements. The peak observed at 730 nm in the PBS extracted samples (Figs. 2C and 4A–4F) was attributed to the second-order diffraction of the scattered incident radiation of 365 nm. Unfortunately, sample-to-sample variations in the magnitude of the observed scattered radiation prohibited its removal through simple blank-subtraction procedures.

Variation in the pH of the PBS solutions yielded visual differences in the recorded fluorescence spectra among the six

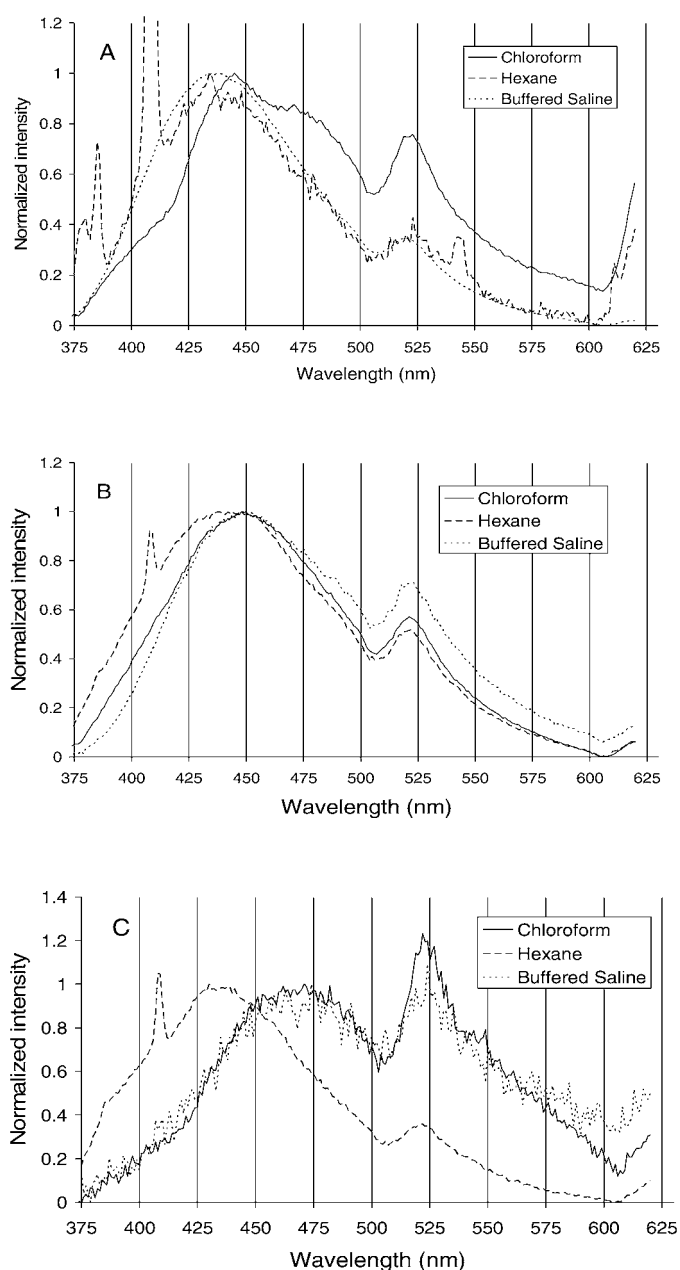

FIG. 3. Mean emission spectra ( $n = 3$ ) for (A) mesa dropseed, a grass; (B) spectacle pod, a forb; and (C) tarbush leaves, a shrub, extracted with three solvents, chloroform, hexane, and phosphate buffered saline, pH = 7.5.

plant species. The sharp peak observed at 418 nm (Figs. 4A–4F) is consistent with a Raman vibrational band for H<sub>2</sub>O in saline solution.<sup>34</sup> Again, efforts to remove this feature through background correction were not successful and resulted in sample-dependent under- and over-correction. The decreased signal intensities shown at ~515 nm for all spectra (Figs. 2–5) can be attributed to the absorption of light by surface plasmons associated with the surface of the holographic grating used for these measurements (i.e., the Wood's grating anomaly<sup>30–32</sup>). Interestingly, a similar spectral feature was reported by Chappelle et al.<sup>12</sup> for spectra from species of corn and soy beans after correcting for wavelength-dependent detection variances. Again, the purpose of the present study was to investigate the feasibility of using luminescence emission spectra to distinguish among forage plants. It was therefore

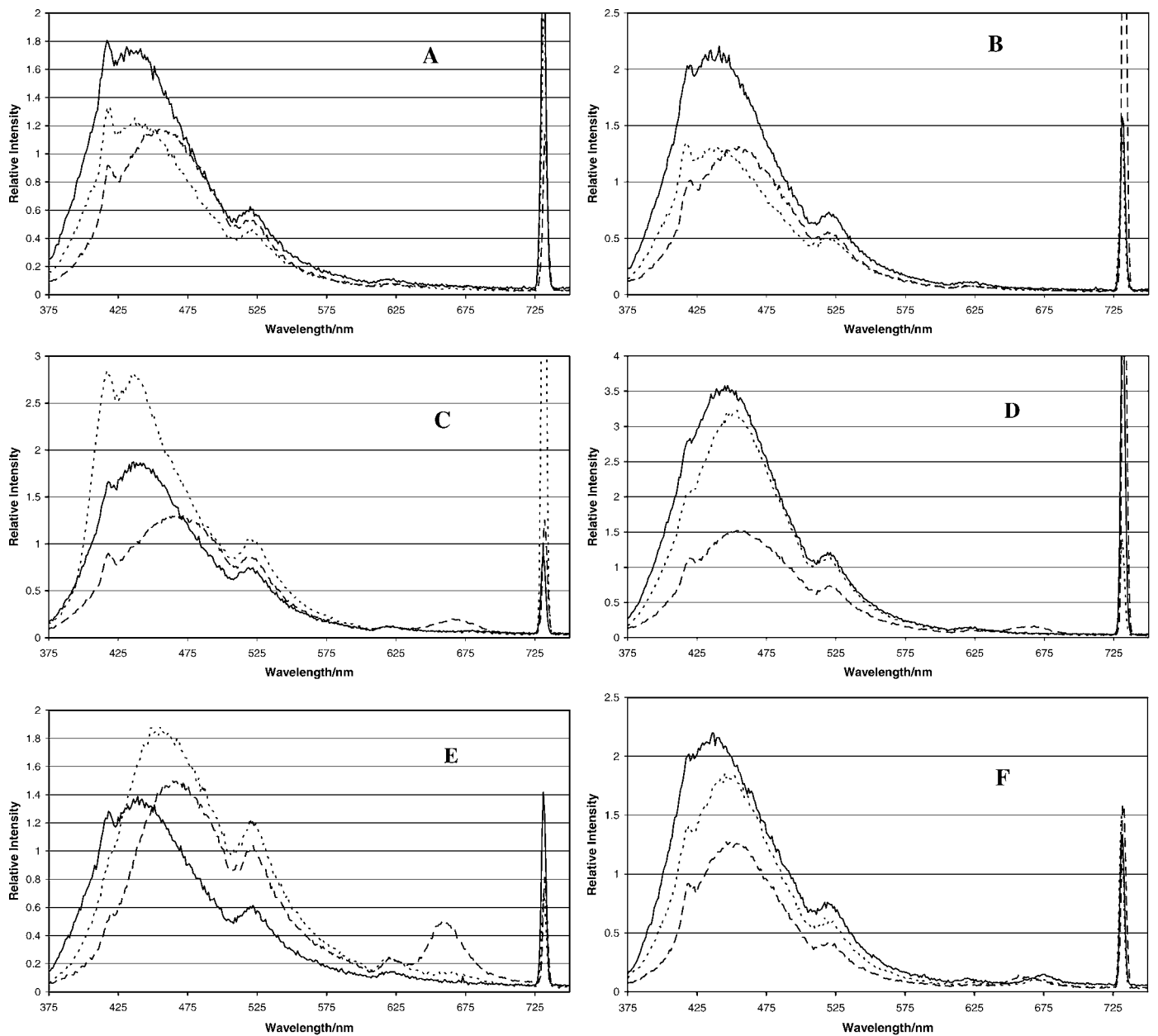

FIG. 4. Mean emission spectra ( $n = 3$ ) for extracts of (A) *Sporobolus flexuosus* (Thurb. ex Vassey) (mesa dropseed, a grass), (B) *Pleuraphis mutica* Buckley (tobosa, a grass), (C) *Dimorphocarpa wislizenii* (Engelm.) Rollins (spectacle pod, a forb), (D) *Sphaeralcea incana* Torrey (pale globemallow, a forb), (E) *Flourensia cernua* DC (tarbush leaves, a shrub), and (F) *Atriplex canescens* (Pursh) Nutt. (fourwing saltbush leaves and stems, a shrub) using phosphate buffered saline at three different pH values: (—) 2.2, (····) 7.5, and (- - -) 12.5.

decided that no effort to correct for this constant effect would be made within the present study.

Excluding these sample-independent features, local maxima are observed at wavelengths of 439, 447–456, 470, 620, and 660–680 nm (Figs. 4A–4F). These were observed to vary with both the plant species and solution pH. The spectra from the two grass species (mesa dropseed and tobosa, Figs. 4A and 4B, respectively) contained local maxima at ~440 and ~620 nm with PBS pH values of 2.2 and 7.5 but demonstrated a red-shift of the 440 nm peak to ~456 nm while leaving the feature at 620 nm unchanged in terms of its location. This, with a significant decrease in the measured emission signal, suggests diminished extraction efficiency of those molecular species exhibiting blue photoluminescence. Although the locations of

the spectral features for these two grass species were very similar, variations in the relative contributions of the molecular components of the solutions responsible for each region of their spectra suggests the possible use of photoluminescence to distinguish between these plant species.

Comparison of the spectra from the two forbs (spectacle pod and pale globemallow, Figs. 4C and 4D, respectively), reveals greater variability between species for the different solution pH values. Both species yielded a spectral feature at ~620 nm for each pH condition but showed a peak at about 670 nm only at pH 12.5. Additionally, while the blue fluorescence peak for pale globemallow exhibited a slight red-shift (i.e., 447 to 453 nm) with increased pH from 2.2 to 7.5 (Fig. 4D), the corresponding feature in the spectacle pod spectra showed a comparable blue-

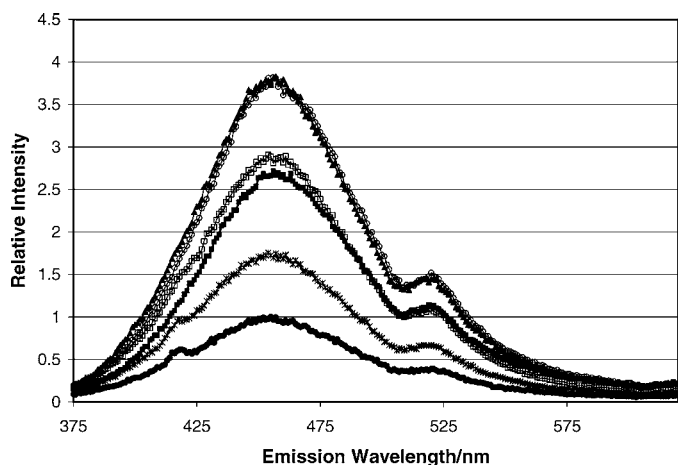

Fig. 5. Relative luminescence intensities for PBS extracts of pale globe-mallow at pH = 7.5 as a function of relative solution concentration corresponding to the extraction of effective amounts of plant material in 10.0 mL PBS: (■) 150 mg, (○) 75 mg, (▲) 30 mg, (□) 15 mg, (×) 7.5 mg, and (●) 3.75 mg.

shift from acidic to near-neutral pH conditions (441 to 436 nm for pH 2.2 to 7.5, respectively) and a significant red-shift under basic conditions (469 nm at pH 12.5, Fig. 4C). This also suggests a variability in the extraction efficiency of blue-fluorescence compounds as a function of both solution pH and plant species and an increased extraction efficiency for a red-fluorescing compound when excited at 365 nm.

Increasing the pH of the extracting PBS solution resulted in a measurable red-shift in the blue portion of the fluorescence signatures of the two shrubs, tarbush and fourwing saltbush (Figs. 4E and 4F, respectively). The spectra from tarbush leaves yielded peaks at ~439, 455, and 470 nm as the solution pH was varied from 2.2 to 7.5 to 12.5, respectively. Alternately, the corresponding spectral feature arising from the fourwing saltbush samples shifted from 437 nm to 447 nm as the solution was changed from acidic (pH 2.2) to slightly basic (pH 7.5). The location of this maximum then remained at 447 nm for the pH 12.5 solution. Both plant species yielded features at about 622 and 660 nm. However, the tarbush samples exhibited a significant feature at 660 nm under basic conditions (pH 12.5) compared to the near-baseline feature for the fourwing saltbush under the same extraction conditions. Conversely to the spectra of any other plant studied, the spectrum arising from the fourwing saltbush samples revealed a peak, albeit small, at 676 nm under acidic conditions (pH 2.2). These data suggest that although the extraction efficiency of blue-fluorescing species decreases with increasing pH, the extraction of other molecular species appears to be enhanced with more basic conditions. Additionally, there appears to be additional red fluorescing compounds that exhibit varied pH-dependent extraction efficiencies.

Previous studies have used the combination of blue-green and red fluorescence ratios to provide information on stress and photosynthetic pathways.<sup>16</sup> Because the total chlorophyll concentration depends on many variables, the red fluorescence signal can fluctuate. This fluctuation has been used to correlate stress factors with observed red fluorescence.<sup>17–19</sup> Because chlorophyll can also re-absorb the blue fluorescence, its concentration can also affect the recorded blue fluorescence signal.

As stated above, the use of PBS as an extraction solvent reduced the detectable chlorophyll in the sample extracts.

Although chlorophyll concentrations can be indicative of a plant's growing conditions, it is a less desirable variable for the identification of plants using their fluorescence signatures.

Concentration differences or slight variations in the chemical binding of presently unidentified fluorophores within the extracts yield different spectra for the individual plant life forms. Spectral differences among the selected species within each life form, grasses, forbs, and shrubs, made it possible to qualitatively separate species by their fluorescence signatures.

Figure 3 shows the normalized mean spectra obtained for three of the six plant species evaluated. Figure 3A illustrates the differences in the spectral patterns of the three plant life forms. Spectacle pod, a forb, exhibited one broad asymmetric peak centered at ~484 nm. In comparison, the spectrum from tobosa hay contains a distinct shoulder at ~453 nm with a broad central peak at ~489 nm. Alternately, extracts from samples of tarbush leaves, a shrub, yielded the most distinguishing fluorescence spectrum by exhibiting local maxima at 489 and 549 nm. The shoulder feature visible in the tobosa spectrum was also not observed in the tarbush leaf sample spectra.

These data suggest the presence of multiple fluorophores with at least one unique molecule for each fluorescence emission band (three to four for the tarbush leaf extracts). An alternate explanation could be the presence of one molecule with multiple emission bands. However, given the molecular complexity of plant tissues described in other studies,<sup>35</sup> the accuracy of such a simplistic explanation is dubious. Even so, the existence of multiple fluorophores<sup>35</sup> would suggest that each plant species could have different contributions from each fluorophore. These contributions may be in the form of different amounts (i.e., concentrations) of each fluorophore. This would enable the application of a peak ratio analysis of the emission spectra<sup>14</sup> to be a viable method to differentiate among pre-digested and possibly post-digested filtrates. There could also be different binding sites of these molecules within different plant species; this could produce a wavelength (chemical) shift to the center wavelength ( $\lambda_{\text{max}}$ ) of the luminescence emission peaks.

It was hypothesized that some of these observed variances in the recorded spectra from the different sample solutions could result from post-filter effects resulting from the presence of other chromophores in the extract solutions. To investigate this possibility, sample solutions were systematically diluted and their corresponding luminescence spectra recorded. Dilutions were undertaken through the removal of a known volume of a solution within the sample cuvette and the subsequent addition of the same volume of the PBS solution with the same pH value. The initial solution from extraction of 150.0 mg of the plant material with 10 mL of the PBS solution was first diluted by a factor of two (i.e., one part of the original solution with an equal volume of PBS solution). The second dilution resulted in a sample that was 20% the concentration of the original solution (i.e., a 1 to 4 dilution). Subsequent dilutions were prepared by a two-fold dilution of the previous solution in the sequence.

The spectra shown in Fig. 5 are representative of the results of that study. Readily apparent from these data are two observations. The first and most obvious effect was that dilution of the sample resulted in a significant increase in the measured fluorescence intensity with a two-fold dilution of the original extract solution, with little change in signal intensity

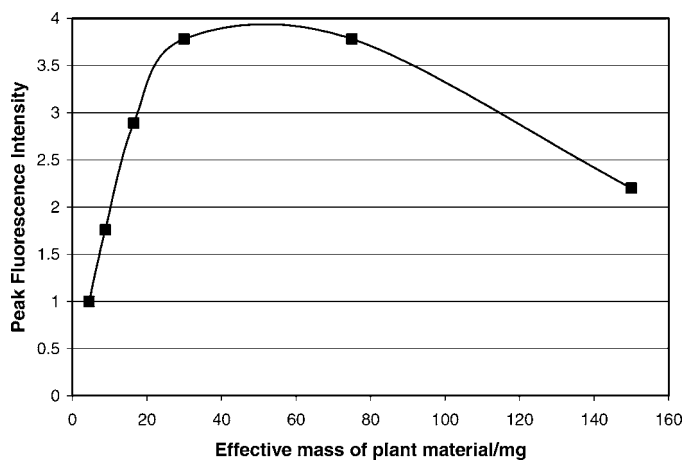

FIG. 6. Relative peak intensities as a function of effective sample mass for conditions described in Fig. 5.

for the five-fold diluted sample (corresponding to the extraction of 30 mg of plant material with 10 mL of the PBS solution). Further dilution then resulted in a general decrease in the measured intensities (Fig. 6). The second effect is evident at the wavelength corresponding to the water Raman peak. Although the amount of water in the observation volume of each sample was constant, the contribution of the Raman scattering to the observed spectrum was not constant throughout the sample dilution sequence. Based on these observations, it was concluded that the observed fluorescence spectral signature for each plant is not only the result of varying contributions of fluorescent molecular species in the extract solutions but also due to plant-species-dependent amounts of chromophores (i.e., light absorbing species) in those extracts.

Based on spectra from these plant samples, it appears that photoluminescent distinction among plant life forms may have value in differentiating among different clipped plant species growing on arid range land.

Although the above method of visual spectral comparison is strongly suggestive of the ability of luminescence spectra to identify plant species, it is neither quantitative nor conclusive. In an effort to better quantify the differences (or similarities) among such spectra signatures, principal component analysis (PCA) was applied to the emission spectra.

Figure 7 shows the projection of each of the two-dimensional spectra into a three-dimensional principal component coordinate space (PC-space). These three principal components were derived from the eigenvalues associated with a matrix of the emission intensities at each wavelength of each plant species ( $\lambda_{\text{excitation}} = 365 \text{ nm}$ ). These components (PC1, PC2, and PC3) accounted for 77.05%, 17.45%, and 3.90%, respectively, of the variance associated with the data. This PCA model was then able to account for a total of 98.40% of the variance.

Readily apparent from Fig. 7 is the relatively broad distributions of these plant species throughout this PC-space. Greater separation between the projected points is indicative of more significant differences between the corresponding spectra. Most notable among these results are the groupings in the PC-space for each of the three life forms (i.e., grasses, forbs, and shrubs). Although this model was not able to distinguish between the two grass species at this pH (mesa

Scores on PC 3 (3.90%)

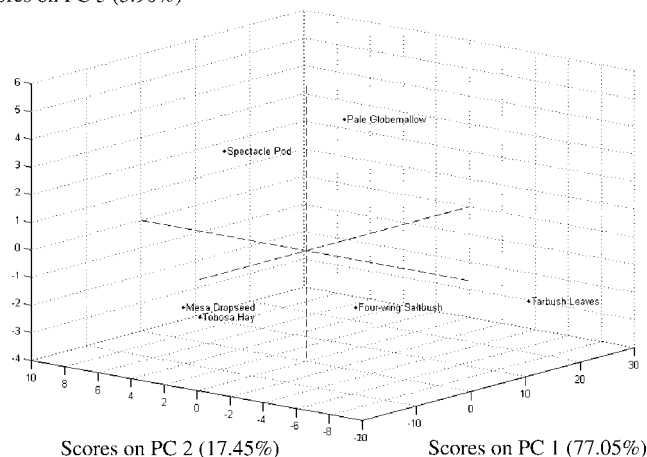

FIG. 7. Application of principal component analysis to averaged emission spectra ( $n=9$ ) of extract solutions of phosphate buffered saline at pH 12.5 from each of the six plant species studied.

dropseed and tobosa hay), a visual comparison of the spectra of extract solutions for each of these plants suggest the utility of this added dimension as a potential means of distinguishing between them.

#### ACKNOWLEDGMENTS

The authors wish to acknowledge the United States Department of Agriculture–Agriculture Research Service, Jornada Experimental Range, The International Arid Lands Consortium (Project No. 03R-03), and the Bureau of Land Management for financial assistance.

1. G. S. Holechek, M. Vavra, and R. D. Pieper, *J. Range Manage.* **35**, 309 (1982).
2. A. J. Bjugstad, H. S. Crawford, and D. L. Neal, Range and Wildlife Habitat Evaluation, A Research Symposium, U.S. Forest Service, Misc. Pub. 1147, (U.S. Government Printing Office, Washington, D.C., 1970), pp. 101–104.
3. *Research techniques in use at the Grassland Research Institute Hurley. Field experiments*, Commonwealth Bureau of Pastures and Field Crops, Hurley, Berkshire, England, Bull. 45 (Commonwealth Agricultural Bureaux, Farnham Royal, Bucks, England, 1961), Chap. 6.
4. D. R. Sparks and J. C. Malechek, *J. Range Manage.* **21**, 264 (1968).
5. G. S. Howard and M. J. Samuel, U.S. Department of Agriculture Tech. Bul. **1582**, 143 (1979).
6. L. E. Green, L. H. Blankenship, V. F. Cogar, and T. McMahon, *Texas Agr. Exp. Stn.*, RM14/KS6 160 (1985).
7. W. J. Foley, A. McIlwee, I. Lawler, L. Aragonas, A. P. Woolnough, and N. Berding, *Oecologia* **116**, 293 (1998).
8. L. Nørgaard, *Zuckerind* **120**, 970 (1995).
9. W. D. Pitman, C. K. Piacitelli, G. E. Aiken II, and F. E. Barton, *Agron. J.* **83**, 103 (1991).
10. J. W. Walker, D. H. Clark, and S. D. McCoy, *J. Range Manage.* **51**, 450 (1998).
11. A. J. Smart, W. H. Schacht, and J. F. Pedersen, *J. Range Manage.* **51**, 447 (1998).
12. E. W. Chappelle, F. M. Wood, Jr., J. E. McMurtrey III, and W. W. Newcomb, *Appl. Opt.* **23**, 134 (1984).
13. H. K. Lichtenthaler and J. Schweiger, *J. Plant Physiol.* **152**, 272 (1998).
14. H. K. Lichtenthaler, M. Lang, M. Sowinska, F. Heisel, and J. A. Miehé, *J. Plant Physiol.* **148**, 599 (1996).
15. F. Babani, H. K. Lichtenthaler, and P. Richter, *J. Plant Physiol.* **148**, 471 (1996).
16. A. Barócsi, L. Kocsányi, S. Várkonyi, P. Richter, and Z. Csintalan, *Meas. Sci. Technol.* **11**, 717 (2000).
17. H. K. Lichtenthaler and J. A. Miehé, *Trends Plant Sci.* **2**, 316 (1997).
18. F. Stober and H. K. Lichtenthaler, *Physiol. Plant.* **88**, 696 (1993).
19. F. Stober and H. K. Lichtenthaler, *Bot. Acta* **106**, 365 (1993).
20. Z. G. Cerovic, G. Samson, F. Morales, N. Tremblay, and I. Moya, *Agronomie* **19**, 543 (1999).

21. E. Billa, A. Pastou, B. Monties, J. Romero, and E. G. Koukios, *Indust. Corps Products* **11**, 187 (2000).
22. E. Billa, E. Koutsoula, and E. G. Koukios, *Bioresource Technol.* **67**, 25 (1999).
23. L. Munck, L. Norgaard, S. B. Engelsen, R. Bro, and C. A. Andersson, *Chemom. Intell. Lab. Syst.* **44**, 31 (1998).
24. P. Seiden, R. Bro, L. Poll, and L. Munck, *J. Agric. Food Chem.* **44**, 3202 (1996).
25. D. Baunsgaard, L. Munck, and L. Norgaard, *Appl. Spectrosc.* **54**, 438 (2000).
26. D. M. Anderson, P. Nachman, R. E. Estell, T. Ruekgauer, K. M. Havstad, and L. W. Murray, *Small Rumin. Res.* **21**, 1 (1996).
27. D. M. Anderson, E. L. Fredrickson, P. Nachman, R. E. Estell, K. M. Havstad, and L. W. Murray, *Anim. Feed Sci. Technol.* **70**, 315 (1998).
28. T. L. Danielson, G. D. Rayson, D. M. Anderson, R. Estell, E. L. Fredrickson, and B. S. Green, *Talanta* **59**, 601 (2002).
29. L. R. Drake, T. R. Baker, P. C. Stark, and G. D. Rayson, *Instrum. Sci. Technol.* **23**, 57 (1995).
30. L. B. Mashev, E. K. Popov, and E. G. Loewen, *Appl. Opt.* **27**, 152 (1988).
31. S. Mori, K. Mukai, J. Yamakita, and K. Rokushima, *J. Opt. Soc. Am. A* **7**, 1661 (1990).
32. S. A. Coulombe and J. R. McNeil, *J. Opt. Soc. Am. A* **16**, 2904 (1999).
33. B. Valeur, *Molecular Fluorescence* (Wiley-VCH, Weinheim, 2002).
34. J. Dubessy, T. Lhomme, M. C. Boiron, and F. Rull, *Appl. Spectrosc.* **56**, 99 (2002).
35. O. S. Wolfbeis, "The Fluorescence of Organic Natural Products", in *Molecular Luminescence Spectroscopy. Methods and Applications: Part 1*, S. G. Schulman, Ed. (John Wiley and Sons, New York, 1985), pp. 167–370.